

Air Flow Measurement

1. Air Flow Physics

Air is a mixture of 78% nitrogen (N_2), 21% oxygen (O_2), water vapor H_2O (depending on relative humidity) and small fractions of other gases (Ar, CO_2 , H_2 , Ne, He, Kr). A single gas molecule with mass m [kg] can get into motion and acquire kinetic energy E_{kin} [J]

$$E_{kin} = \frac{1}{2} \cdot m \cdot v^2$$

by a pressure difference [mbar] produced e.g. by a ventilation system. The pressure gradient leads to an air flow from the high pressure region to the low pressure region for establishing a pressure balance. The molecule's travelled distance per time defines its velocity v . The velocities of the single molecules are statistically distributed but an "air velocity" can be defined by the mean velocity value of N molecules i.e.

$$\bar{v} [m/s] = \frac{1}{N} (\vec{v}_1 + \vec{v}_2 + \dots + \vec{v}_N)$$

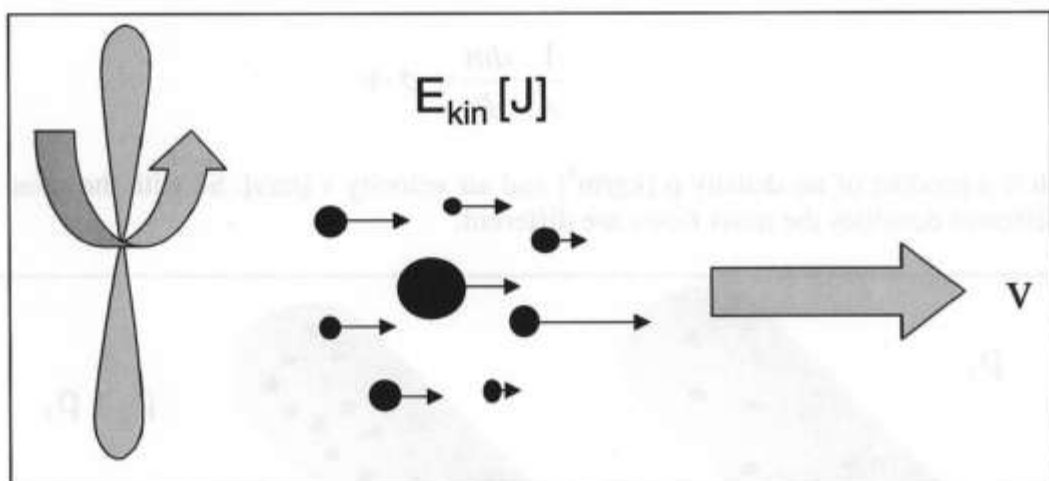

When a free air flow is blown into a pipe, the air velocity inside is not uniform in space but decreases parabolically from the tube's central axis towards the walls: molecules stick to the tube's walls due to friction and equally layers made of fluid molecules are in contact and rub against each other which gives "viscosity" η [kg/(m·s)]. Usually it is recommended to measure right in the middle of the tube, where the influence of the walls is a minimum and you should get the maximum value of velocity.

Whenever an air flow faces a local barrier the flow follows locally the leading edges of the body and the velocity is changed there. Especially in the wake of the body the flow can become very special.

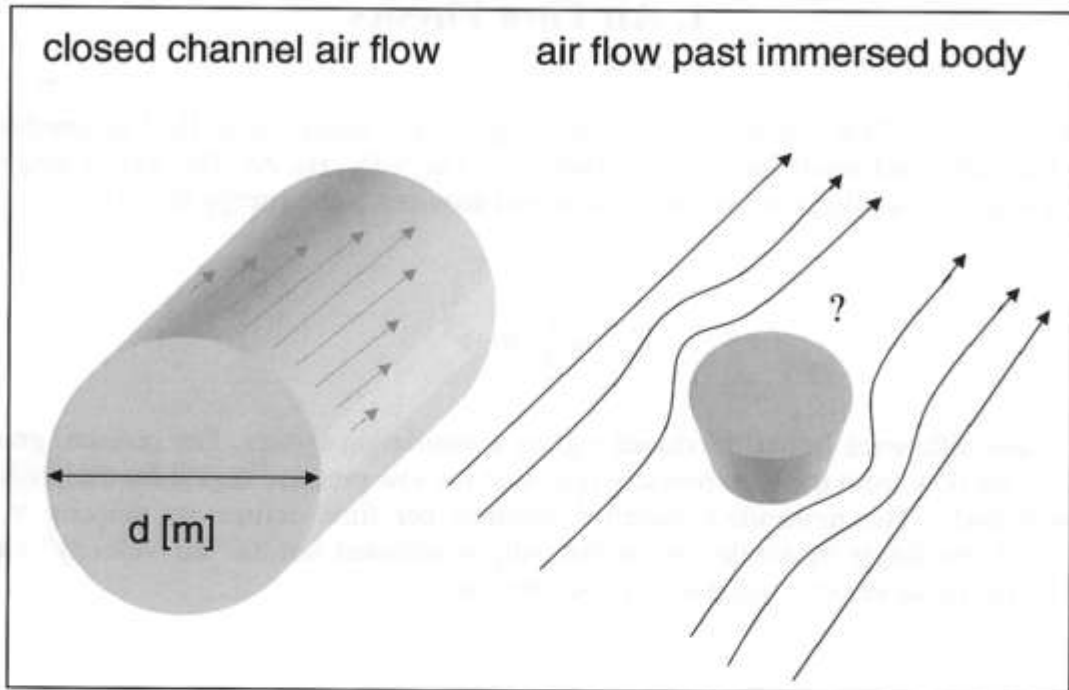

In many fluid applications it is not the velocity which is of interest but a quantity rate e.g. the mass flow dm/dt [$kg/(m^2 \cdot s)$] i.e. the transferred mass per time and area $A[m^2]$

$$\frac{1}{A} \cdot \frac{dm}{dt} = \rho \cdot v$$

which is a product of air density ρ [kg/m^3] and air velocity v [m/s]. So with the same velocity but different densities the mass flows are different.

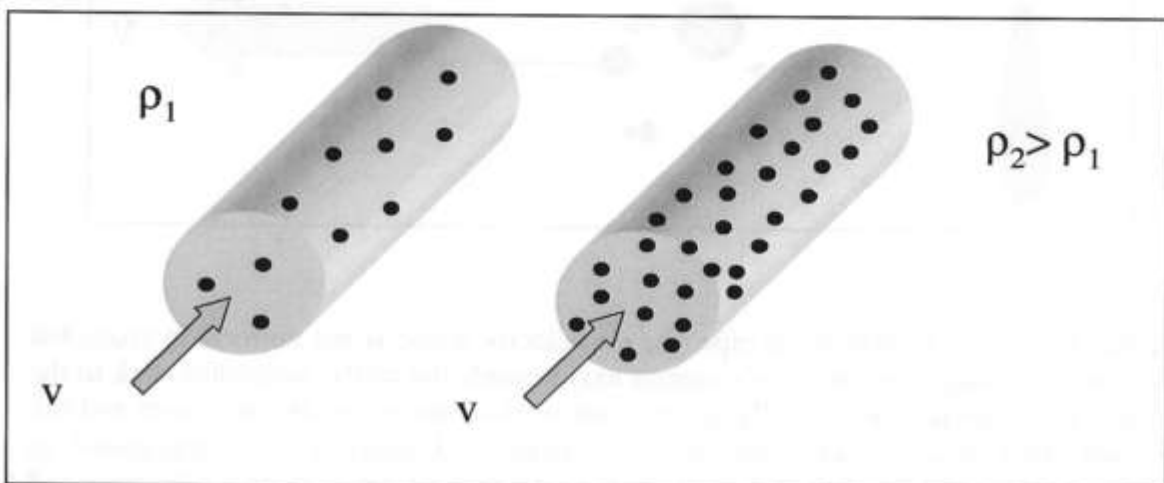

At low enough velocities a free flow or a flow in a pipe is regular ("laminar regime") which means that all molecules follow the same way in parallel direction. At some maximum velocity however their motion becomes irregular, they intermix and form vortices (swirls, eddies) which are not stable in time and space and not predictable ("turbulent regime"). Usually (air) flowmeters do not work in this flow regime.

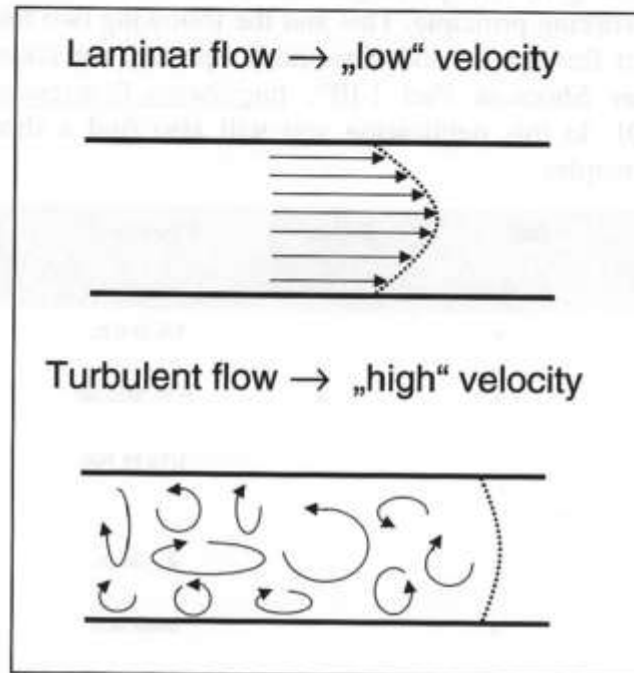

For a turbulent air flow in a tube the velocity profile is more flat i.e. velocity does not change as much from the center to the tube wall as in the laminar regime. The velocity at which the transition from laminar to turbulent occurs is influenced by the diameter d [m] of the tube, the density ρ [kg/m³] and the viscosity η [kg/m·s] of the fluid. This is described by the dimensionless "Reynolds Number" Re , which gives the ratio of inertial (driving) force and viscous (friction) force

$$Re = \frac{d \cdot v \cdot \rho}{\eta}$$

If the Reynolds number exceeds a critical value, which is different for different geometries ($Re_{critical}=2000$ for unimpeded tube flow), the flow starts to become turbulent. The laminar velocity regime can be extended by decreasing the tube's diameter d or by smaller gas density or higher viscosity. A body which blocks the air flow can be source of local accelerations and local partial flows which can lead into turbulence.

2. Typology of (Air) Flowmeters

Air velocimeters are found among flowmeters for gas and liquids giving output values in various flow quantities like mass-, volume-, particle flow(rate), static / dynamic pressure or velocity. Every type of flowmeter is based on a physical principle that works best under typical "paradigm" flow conditions. So the paradigm conditions of the used instrument should fit to the conditions of the actual application to make a proper measurement principally possible. The table below gives the paradigm conditions of the different flowmeter types, listed by their physical working principle. This and the following two tables, which give pros and cons of the different flowmeters and customer's opinion, are taken from an article by Jesse Joder ("Flowmeter Shootout Part I-III", <http://www.flowresearch.com/articles.htm>) published in spring 2001. In this publication you will also find a short description of the flowmeter's working principles.

Flowmeter Type	Gas	Steam	Pipe size	Clean Fluid	Dirty Fluid
Coriolis	x	x	1/6 to 6 in,		Ltd.
Differential Pressure	x	x	1/2 in. and up	x	Ltd.
Magnetic	x		1/10 to 100	x	x
Positive Displacement	x	x	2 – 30 in.	x	
Thermal(HF, HW, Calor.)	Ltd.	x	Insertion	x	No problem for hot film !
Turbine	x	x	2 – 30 in.	x	
Ultrasonic-Transit Time	x	x	1/2 inch and	x	Ltd.
Ultrasonic-Doppler	x		1/2 inch and		x
Vortex	x	x	1/2 inch to 12	x	

Among the group of thermal flowmeters only the calorimetric flowmeters are appropriate for both liquid and gas whereas hot wires and hot films are usually used only for gaseous fluids. Steam is for most flowmeters a problem because of the high temperatures. Due to the individual construction the application of some flowmeters is seriously restricted by the pipe size especially with the Coriolis flowmeter but with thermal flowmeters only the probe length must fit the pipe size. Dirty fluids are less a problem for hot films than for the classical hot wires: hot films are orientated with the active sensor area parallel to the flow whereas hot wires face the flow which favours the accumulation of dirt. Surprisingly there are also instruments which do not work in clean fluids, the reason is, that their measuring principle works with impurities as for the Doppler-effect based instruments - Among them the presently highest standard of flow velocity measurement, the Laser Doppler Anemometer (LDA). The LDA is no common used flowmeter, it's a highly accurate, cost-intensive velocimeter which only pays off for very special applications.



LDA



Vortex



Turbine

Flowmeter Type	Advantages	Disadvantages
Coriolis	High accuracy; Low maintenance; Insensitive to flow profile	High initial cost, depending on size and model; Bent tubes subject to fouling; Not available for pipe sizes over six inches
Differential Pressure	Low initial cost; Ease of installation; Well understood; Many industry approvals	Limited rangeability; Permanent pressure drop; Uses square root method to calculate flowrate; Requires periodic maintenance
Magnetic	Obstructionless; High accuracy; No pressure drop	Cannot meter nonconductive fluids (e.g., hydrocarbons); Relatively high initial cost; Electrodes subject to coating
Positive Displacement	High accuracy; Insensitive to flow profile; High rangeability	Cannot handle dirty fluids; Subject to wear; Pressure drop
Thermal (Hot Film, Hot Wire, Calorimetric)	Relatively low initial cost; Good for low velocity flows	Limited accuracy; Sensitive to dirty fluids except HF !
Turbine	High accuracy; Well-known technology; Medium purchase price	Cannot handle dirty fluids; Bearings subject to wear; Pressure drop
Ultrasonic-Transit Time	High accuracy, depending on model; Obstructionless; Clamp-on convenience; No pressure drop	Limited ability to handle dirty fluids; Can be affected by flow profile; Some models have high initial cost
Ultrasonic-Doppler	Can meter dirty flows; No pressure drop; Clamp-on	Low to medium accuracy; Reynolds number limitations
Vortex	Highly versatile: can measure liquid, gas, and steam; Good accuracy	Limited ability to handle low flows; Vibration can affect accuracy; Few industry approvals

Pitot Tube
(Differential Pressure)



Model DS-400



Ultrasonic-
Transit Time

Flowmeter soft skills →

North American users were asked to rate the importance of factors when specifying or purchasing flowmeters. A scale of 1 to 5 was used, with "5" meaning "most important". The table gives the results.

Criteria	Ranking	Minimum	Maximum
Reliability	4.81	4	5
Compatibility	4.80	4	5
Repeatability	4.78	4	5
Application	4.69	2	5
Technical support	4.67	3	5
User friendly/simplicity	4.60	4	5
Accuracy	4.45	1	5
Maintainability/Repair	4.30	3	5
Price	3.77	1	5

3. Hot Film Technology

There are two principal transmitter constructions :

1. Sensor element with combined velocity and temperature sensor mounted in one single measuring window (EE65).
2. Separate sensor elements for velocity and temperature mounted in two separate measuring windows (EE70). This is the technical more sophisticated version.



The sensor element is a thin glass substrat ($150\mu\text{m}$) partially covered with a structured Mo film ($1\mu\text{m}$) and a protective polyimide layer on top. The Mo film is sputtered onto the cleaned glass substrate and structured by lithographic processing steps.

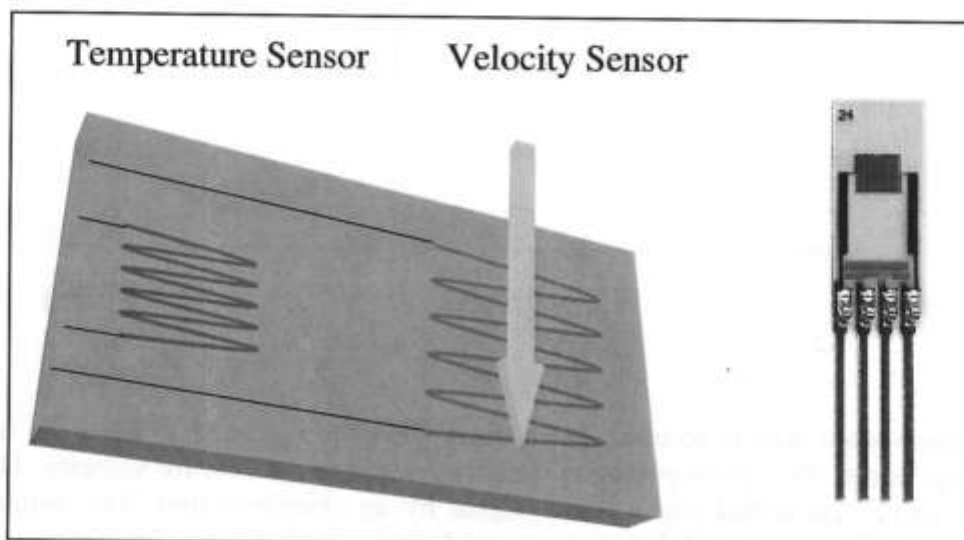

4. Hot Film Measurement Principle

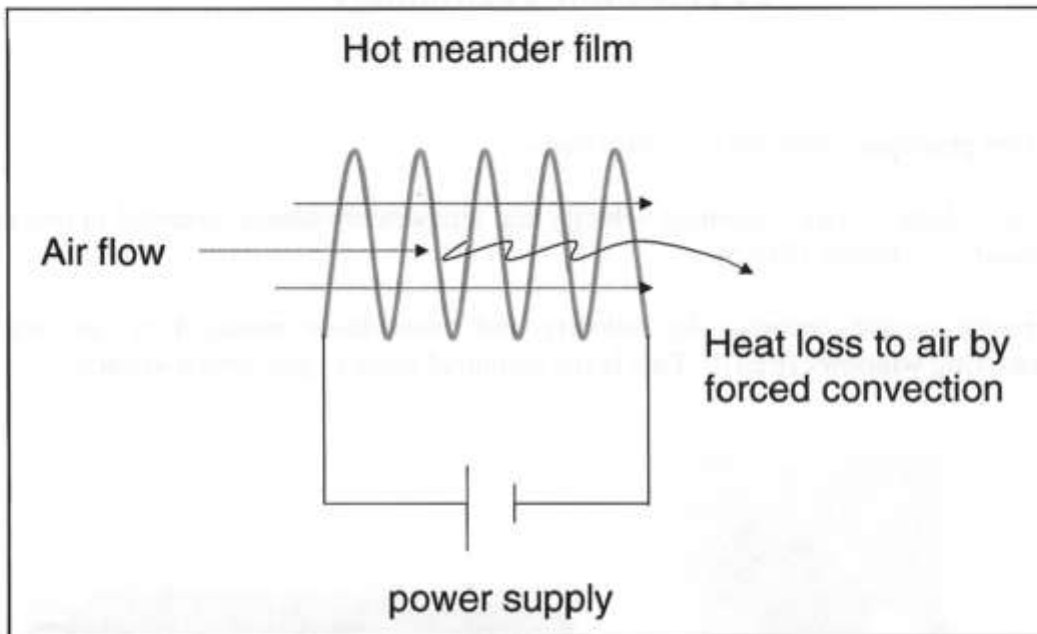

The velocity sensor (“heater”) is a loop-structured Mo film with resistance $R_H[\Omega]$ which is heated up to a temperature $T_h [^{\circ}\text{C}]$ by an electrical power $P=U \cdot I_h=I_h^2 \cdot R_h$ (supply voltage U [V] and heater current I_h [mA]). When an air flow with velocity v and ambient temperature T_a is passing the velocity sensor, heat is transferred from the heater to the air by forced convection. If the power is kept constant, the heater cools down with velocity. Monitoring this characteristic cooling curve would be one way to measure air velocity.

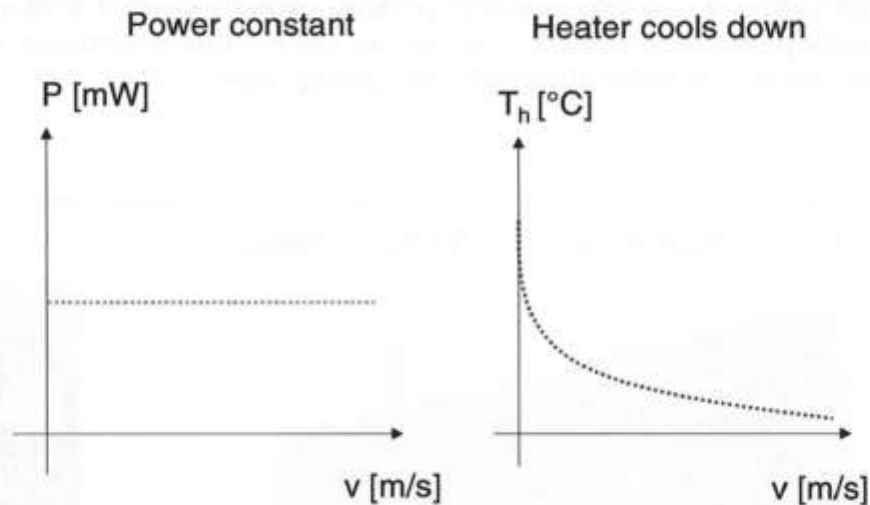

The more appropriate way is to measure contrary the power needed to keep the heater on constant temperature. This gives you again a characteristic curve $P(v)$ for velocity. The signal is nonlinear and is converted into a linear signal by an electronic unit. The output signal, either voltage 0-10V or current 4-20mA, is mapped on a velocity range of 0-20 m/s.

Heater temperature constant Power function of velocity

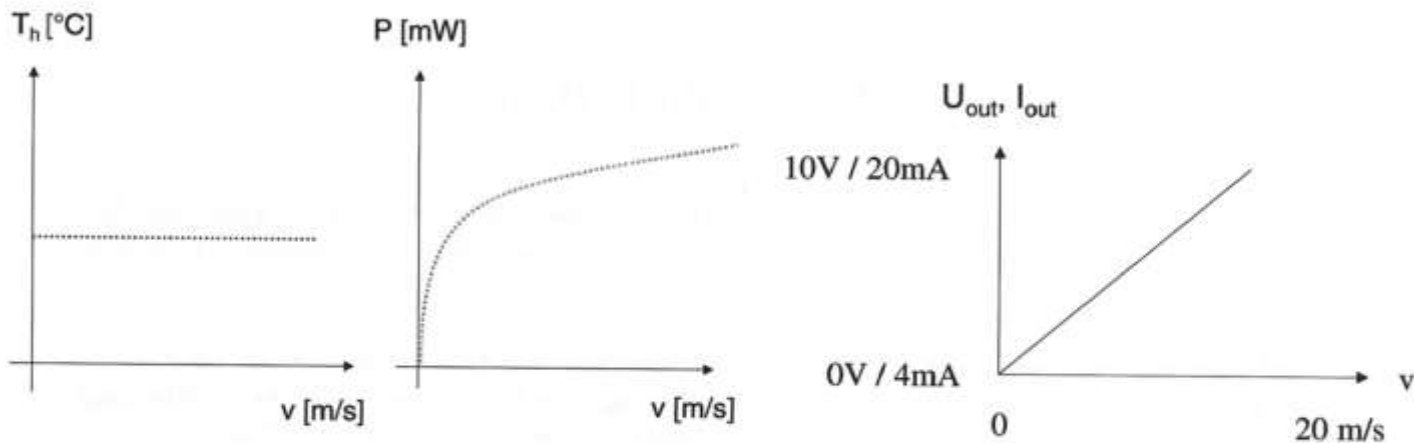

5. Climatic Influences

The amount of convectively transferred heat from the heater to the air flow depends on the temperature difference between the hot film T_h and the temperature T_a of the ambient air.

$$\frac{dQ}{dt} [W] \propto T_h - T_a$$

That is why the difference $T_{ohf} = T_h - T_a$ ("overheating temperature") between the film temperature and air temperature must be kept constant and not purely the heater temperature T_h . This is done electronically either by a microcontroller as with the transmitter EE70 or by using a Wheatstone bridge circuit as with the transmitter EE65. In a Wheatstone bridge the heater and the temperature resistances are wired in parallel and connected in a feedback loop. So a change in ambient temperature T_a affects both heater and temperature sensor at the same time and the bridge will remain in balance.

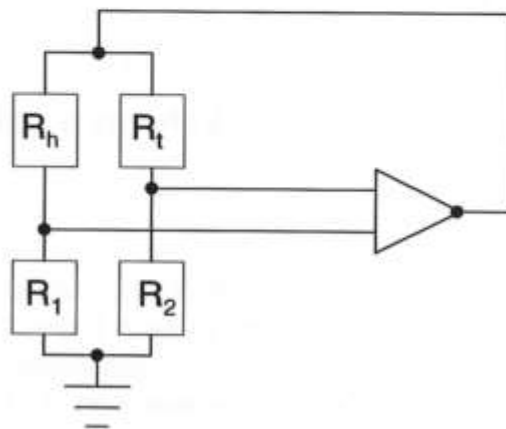

Consequently a temperature measurement is always necessary with hot film anemometry and is naturally done by using the dependance of an electrical resistance R_T [Ω] on temperature t [$^{\circ}\text{C}$]

$$R_T(t) \cong R(0) \cdot (1 + TC \cdot t)$$

The metal resistance depends almost linear on temperature and the slope of the used metal Mo $TC_{Mo}=3380$ ppm/ $^{\circ}\text{C}$ is comparable to that of the conventionally used platinum $TC_{Pt}=3850$ ppm/ $^{\circ}\text{C}$.

All together the transmitter measures the power $P(v)$ which is used to keep up a fixed overheating temperature $T_{ohf} \cong 20\text{-}30^{\circ}\text{C}$. Finally the significant quantity is the "selfheating coefficient" SHC [mW/K] which is power divided by overheating temperature T_{ohf}

$$\frac{1}{SHC} = \frac{P(v)}{T_{ohf}} = \frac{P(v)}{T_h - T_a} = B \cdot v^n$$

The self heating coefficient changes with velocity and from the known, measured characteristic curve you can inversely deduce velocity from the actual value of the self heating coefficient.

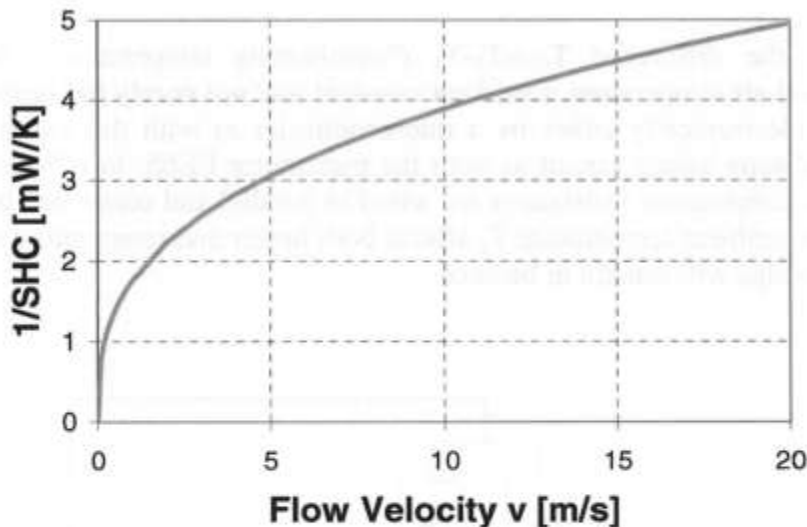

Yet the shape of the characteristic curve $1/SHC(v)$ depends on the specific fluid properties of air i.e. air density ρ [kg/m^3], thermal conductivity λ [$\text{W}/(\text{m}\cdot\text{K})$], viscosity η [$\text{kg}/(\text{m}\cdot\text{s})$] and thermal capacity c_p [$\text{J}/(\text{kg}\cdot\text{K})$] which all more or less change with system temperature and pressure. Fortunately in practice only the dependance on air density (pressure) must be taken into account.

6. Air Pressure – an uncompensated influence

In a simplified picture, neglecting the exact details of heat transfer, the hot film anemometer can be described by a measurement of an air mass flow $[\text{kg}/\text{m}^2 \cdot \text{s}]$ through an area $A[\text{m}^2]$ with velocity v

$$\frac{1}{A} \cdot \frac{dm}{dt} = \rho \cdot v$$

As with an ideal gas the density of air ρ $[\text{kg}/\text{m}^3]$ is proportional to pressure p [mbar] and inversely proportional to temperature T [K]

$$\rho = \rho_0 \cdot \frac{p}{T} \cdot \frac{T_0}{p_0}$$

$\rho_0=1.2922 \text{ kg}/\text{m}^3$, $p_0=1013.25 \text{ mbar}$, $T_0=273.15 \text{ K}$

Consequently the transmitter measures higher virtual velocities $v_m \neq v$ with higher pressures than with calibration pressure p_0

$$v_m = v \cdot \frac{p}{p_0}$$

and the “true” velocity v

$$v = v_m \cdot \frac{p_0}{p}$$

is the measured velocity value v_m multiplied with a correction factor $c(p)=p_0/p$, which depends on pressure.

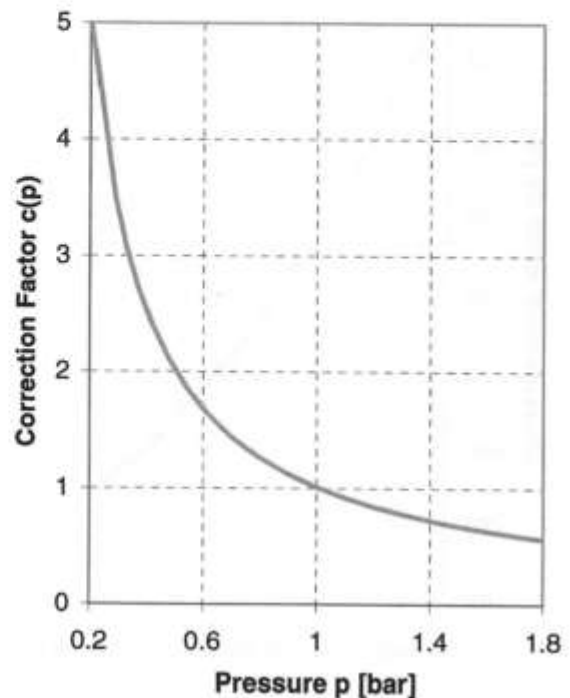
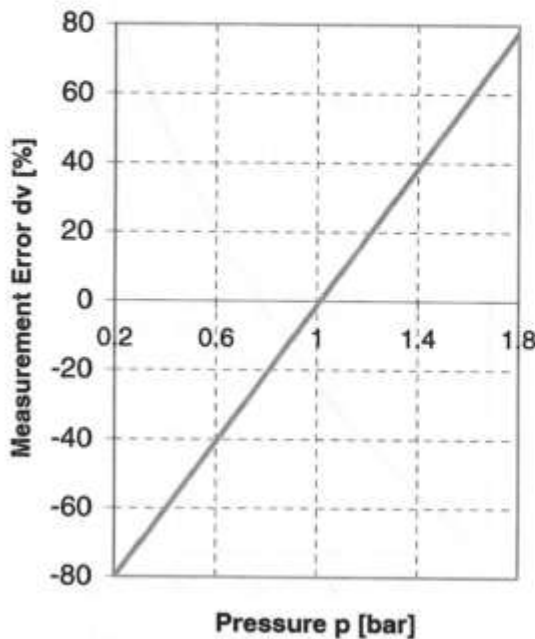

In many applications the system pressure is equal to the atmospheric pressure and so varies with the height above sea level. The air pressure decreases exponentially with increasing height

$$p = p_0 \cdot e^{-\frac{h}{8\text{km}}}$$

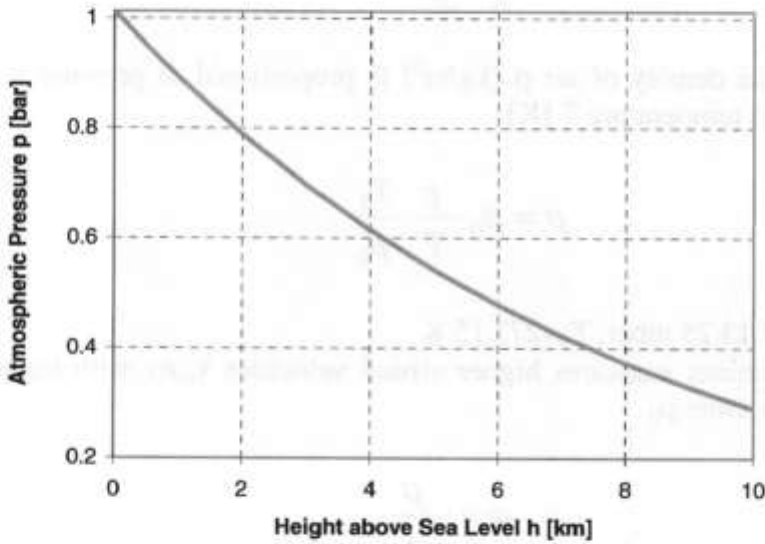

At a height of $h=8$ km the pressure has decreased by a factor $1/e=1/2.718=0.368$ from the value p_0 at $h=0$. Accordingly the velocity value v_m of the transmitter must be corrected by a height-dependant factor $c(h)$ to give the “true” velocity $v=v_m \cdot c(h)$.

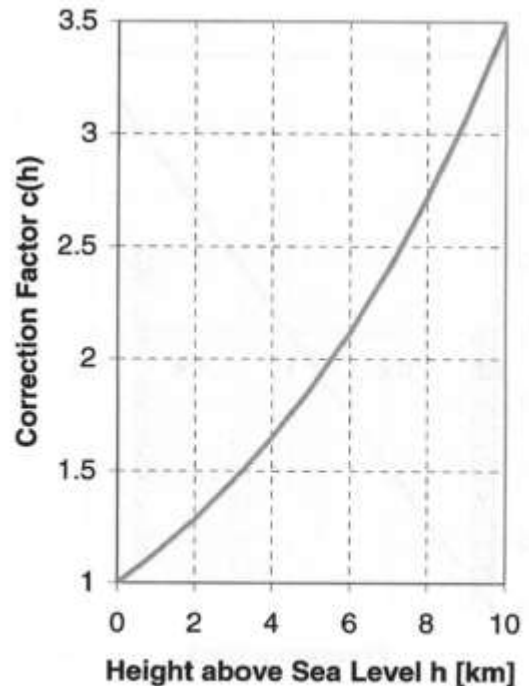
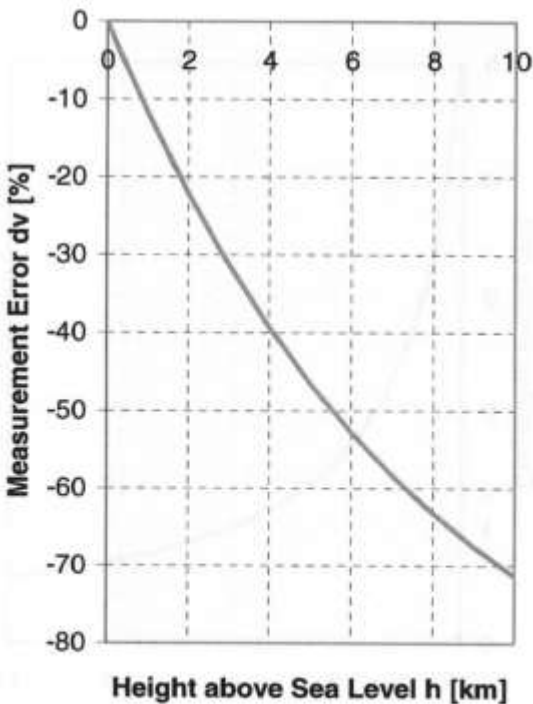

7. Calibration – Wind Tunnel Testing

In the calibration procedure the range of the linear output signal $U_{out} [V] / I_{out}[mA]$ is set to the appropriate velocity range (0-20m/s) for giving the right absolute velocity value in the application. In general a velocity calibration needs (a) a velocity measurement device under test (VDUT) and (b) a velocity reference device with a certificate from an institute providing the national standard of velocity. E+E applies as primary standard a Laser-Doppler-Anemometer (LDA) which is certificated by the PTB (national metrology institute of germany) giving uncertainties of at most 0.2 % in mean velocity. The calibration is the measurement of the deviations of the VDUT from the reference under controlled flow conditions. Controlled flow conditions can be best performed in a wind tunnel.

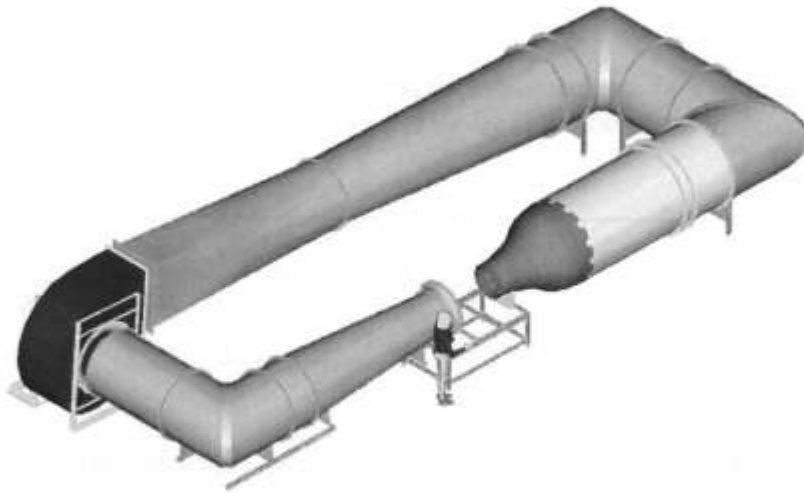

Convenient are open jets (straight path, system open to environment) and closed jets (curved return path, system closed from environment). Both types can have either an open or closed test section. A special tunnel design together with flow forming elements give a uniform, laminar flow in the test section.

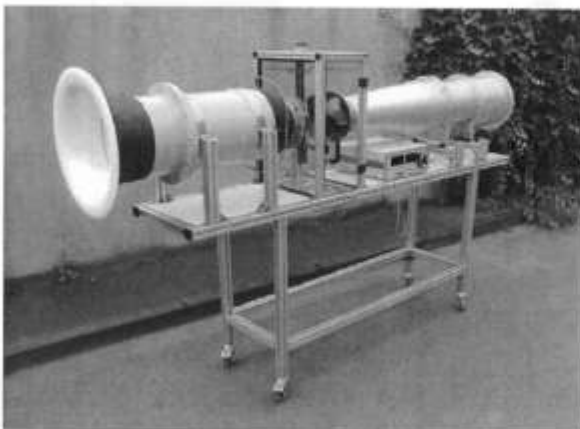

Open Jet



Closed Jet

E+E has two closed jets in operation, one with closed test section (type "Göttingen"), the other with open test section (type "Prandtl"). The velocity range of type "Göttingen" is $v=0-30$ m/s and air temperature can be regulated between $10-40^{\circ}\text{C}$ by an external thermostat. With type "Prandtl" velocities $v=0-40$ m/s can be measured and the ambient temperature is principally fixed to room temperature $T_a \cong 23^{\circ}\text{C}$.

The wind tunnels are not only used for calibration but also for testing the performance of the velocity transmitter under different conditions i.e.

- Climatic conditions : influence of temperature, pressure, humidity
- Geometric conditions : influence of twisting angle, probe position in the flow
- Dynamic conditions : performance under unstable conditions e.g. response time

→ isothermal response time = response time for a change in velocity at constant temperature

→ thermal response time = response time for a change in velocity and temperature

Basic fluid mechanics and experimental experience give some basic rules for a proper velocity measurement in ducts which is given below.

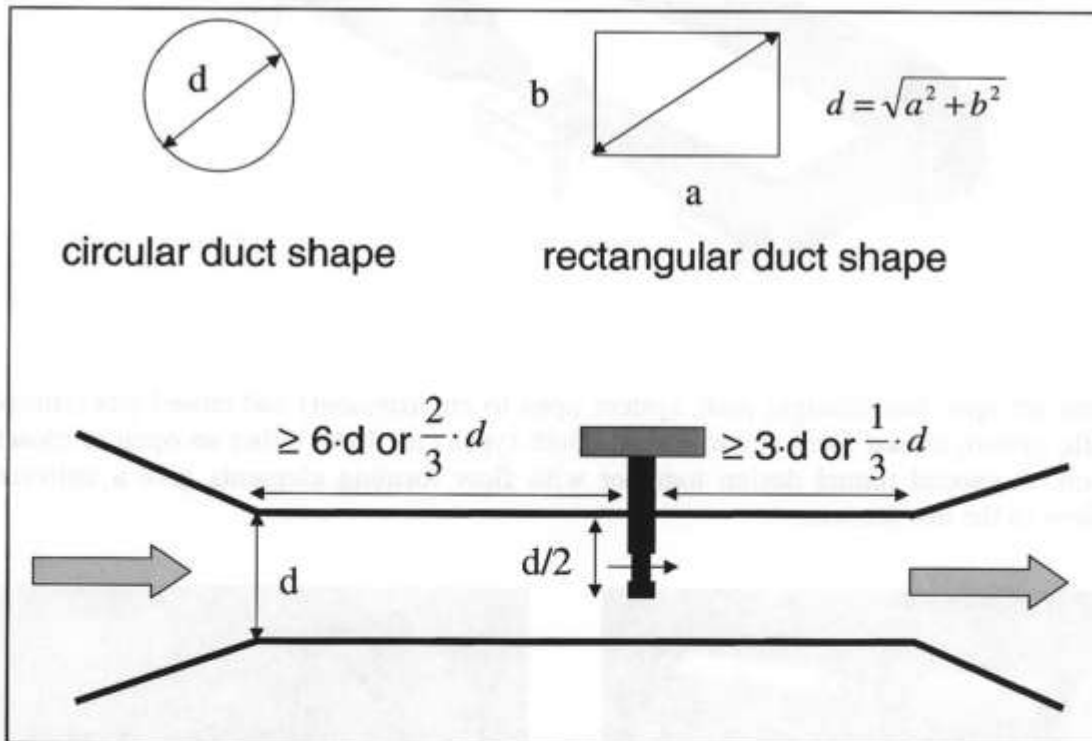

Take care to...

- avoid corners
- avoid walls
- keep parallel to the flow
- avoid flow interrupting elements
- avoid contractions, diffusers

Dont's and Do's

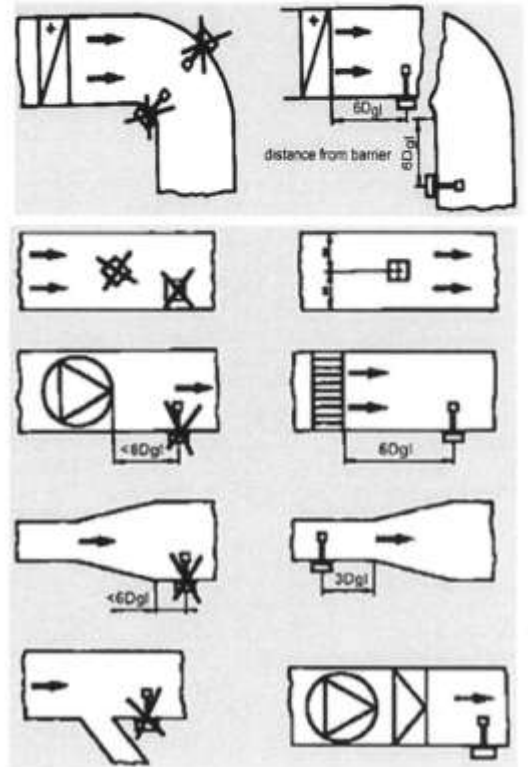

*This paper was written for participants of the E+E Distributor Meeting 26.-29.5. 2004.
For questions and notes contact the author*

*Dr. Erik Thor
E+E Elektronik Ges.m.b.H
Langwiesen 7
A-4209 Engerwitzdorf
Tel.: ++43/7235-605-275
Fax: ++43/7235-605-383
E-mail: erik.thor@epluse.at*